

# KELLENBERGER 1000

Cylindrical Grinding Systems for  
the most Demanding Applications



**KELLENBERGER**  
[WWW.HARDINGE.COM](http://WWW.HARDINGE.COM)

 **HARDINGE®**

# THE INNOVATIVE GRINDING SYSTEM

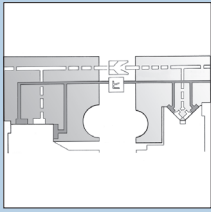

## HYDROSTATICS

- X and Z guideways
- No stick-slip, no wear
- Good damping
- Ultra-fine correction options

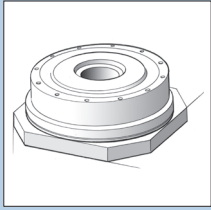

## HYDROSTATIC B-AXIS

- Full-fledged NC axis
- Pre-tensioned hydrostatic guideway
- Direct drive

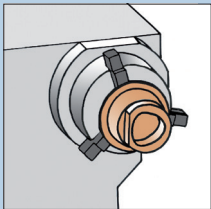

## C-AXIS

- For non-circular workpieces
- For threads
- High-precision spindle bearing
- Direct drive
- High flexibility

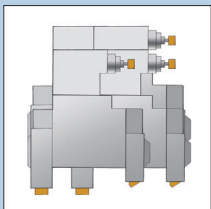

## PLATFORM CONCEPT FOR MORE THAN 20 DIFFERENT WHEELHEADS

- Universal wheelheads
- Diagonal wheelheads
- Tandem wheelheads
- Various mounting positions

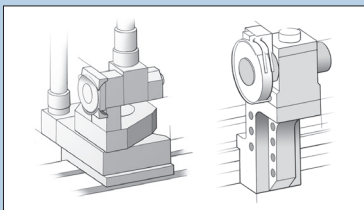

## DRESSING SYSTEMS

- Independent interface at table
- Pivotal unit for chucked work
- Rigid diamonds
- Form and profile dressers



## PRECISION WITH HYDROSTATICS

Hydrostatic guideways and a strict separation of the machine base from the assemblies, generating heat or vibration, provide superb precision and productivity.

The excellent static and dynamic rigidity of the machine base permits a three-point set-up. The Kellenberger 1000 therefore has no particular requirements on the building's foundations. The hydrostatic guides for the longitudinal slide movement (Z-axis) and for wheelslide infeed (X-axis) provide the basis for the machine's extreme accuracy. X- and Z-axis movements are practically frictionless at all speeds. There is no stick slip; even the smallest increments of  $0.1 \mu\text{m}$  can be traveled without a problem, so that the machine features measuring-machine accuracy.

## LARGE WORK SPACE – UNIQUE TABLE CONCEPT

The machine table has been considerably extended so it allows unmatched, optimal positioning of the grinding wheel and a larger travel distance, but also many machining options and application-specific configurations.

## FUNCTIONAL MACHINE CASING

The increased sheet metal thickness means even more process reliability, allowing larger internal grinding wheel diameter of up to 125 mm. With their large viewing windows, the generously-sized doors allow optimum control over the work process and make it easier to access the work space. The genuine glass laminated safety panes require very little maintenance.

# FUNCTIONAL DESIGN WITH HIGHLY PRECISE TECHNOLOGY



## COMPACT AND MAINTENANCE-FRIENDLY

Elements such as the power supply, electrical cabinet, and a central connection point for lubricating coolant, water cooling system, and compressed air were all integrated into the casing. Service and maintenance doors for unimpeded access to machine components are integrated into the back.

## OPTIMIZED ENERGY MANAGEMENT

Performance-optimized central cooling system. Automated procedures for switching on and off. Energy-efficient low-pressure hydrostatics.

## EASY COMMISSIONING

The integrated transportation concept (hook machine) shortens commissioning times considerably.

## MACHINE RE-COOLING SYSTEM

- Comprehensive cooling system with needs-based design (wheelhead & grinding spindles, direct drive, hydrostatics, electric cabinet)
- Increased flow rates at lower system pressure
- Active cooling principle for optimal temperature stability
- Minimized thermal drift, so smaller deviations on workpiece
- Hydrostatic oil cooled to ambient temperature
- Automatic tracking of surroundings, water cooler: Sensor in bed measures reference temperature of regulator

## OPTIONS

- Increased coolant pressure up to 10 bar
- Interface for fire extinguisher system
- Automatic door drive
- Replacement aid for grinding wheels and tailstock

## CONTROL SYSTEM

- Heidenhain GRINDplus 640
- Fanuc 3 li - B
- 19" Touch Screen



## SOFTWARE

- RED Solution
- BLACK CAM Solution

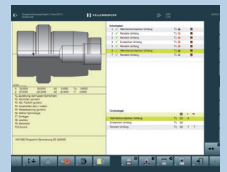

## X/C INTERPOLATION

- Non-circular workpieces
- Thread grinding
- Jig grinding
- Groove grinding

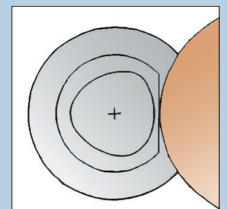

## X/Z INTERPOLATION

- Taper grinding
- Profile grinding
- Dressing

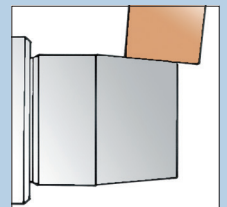

# B-AXIS AND AUTOMATIC GRINDING WHEEL MEASURING SYSTEM

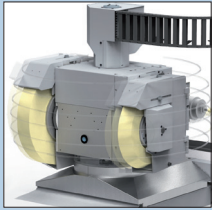

## HYDROSTATIC B-AXIS

- Pre-tensioned hydrostatic guide
- The direct drive is wear-free
- 180° swiveling in one second

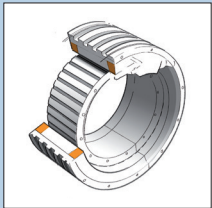

## DIRECT DRIVE SYSTEM

- The water-cooled high-torque motor guarantees a high level of torque
- The rotary encoder is integrated in the absolute measuring system of the machine and requires no referencing

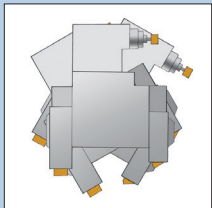

## CLAMPING

- The B-axis can be clamped in any position without any deformation
- The large dimensions of the clamps guarantee high clamping moment

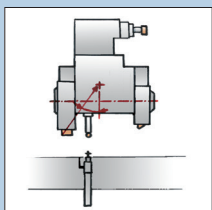

## KEL-SET

- Automatic grinding wheel measuring system
- EU patent No. EP 0542 674 B1
- US patent No. 5.335.454

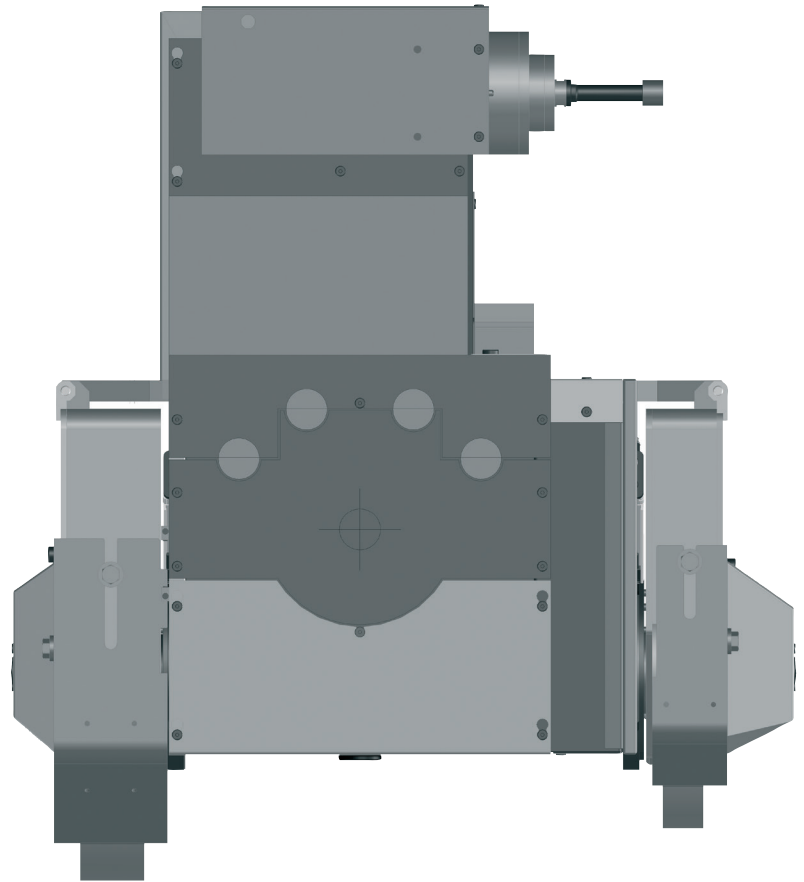

## HYDROSTATIC B-AXIS

Full-fledged NC-axis with pre-tensioned hydrostatic guideway and direct drive.

The pre-tensioned hydrostatic is the basis for higher accuracy and better surface quality. Steps of 0,0001° can be traveled with ease.

## KEL-SET

Automatic grinding wheel measuring system. Movements to the measuring ball and to the grinding wheels occur automatically, with their position information being stored in the control system. When swiveling the wheelhead into any angle, the positions of the grinding wheel edges are automatically taken into account.

## ADVANTAGES FOR THE USER

- Programming takes place with the actual dimensions according to the work drawings and independently of the swivel angle of the wheelhead

- No need for renewed calibration of the swiveled grinding wheel
- Simple and fast acquisition of the grinding wheel data when retooling the machine
- Integrated tool management for external, face and internal grinding

## WORKHEAD

Robust and rigid design on a solid base. Strong motor. Infinitely variable spindle speed. Airlock seals prevent ingress of dirt or water as well as the formation of condensation.

- Excellent roundness and dimensional accuracy thanks to pre-tensioned high-precision antifriction bearings
- Roundness of the workpiece  $dR < 0.4 \mu\text{m}$  ( $< 0.016 \mu\text{inch}$ ) on chucked work
- Versatile in use
- Comes standard with fine adjustment for cylinder correction for chuck work
- ISO 702-1 spindle nose

# WORKHEAD, C-AXIS AND TAILSTOCK

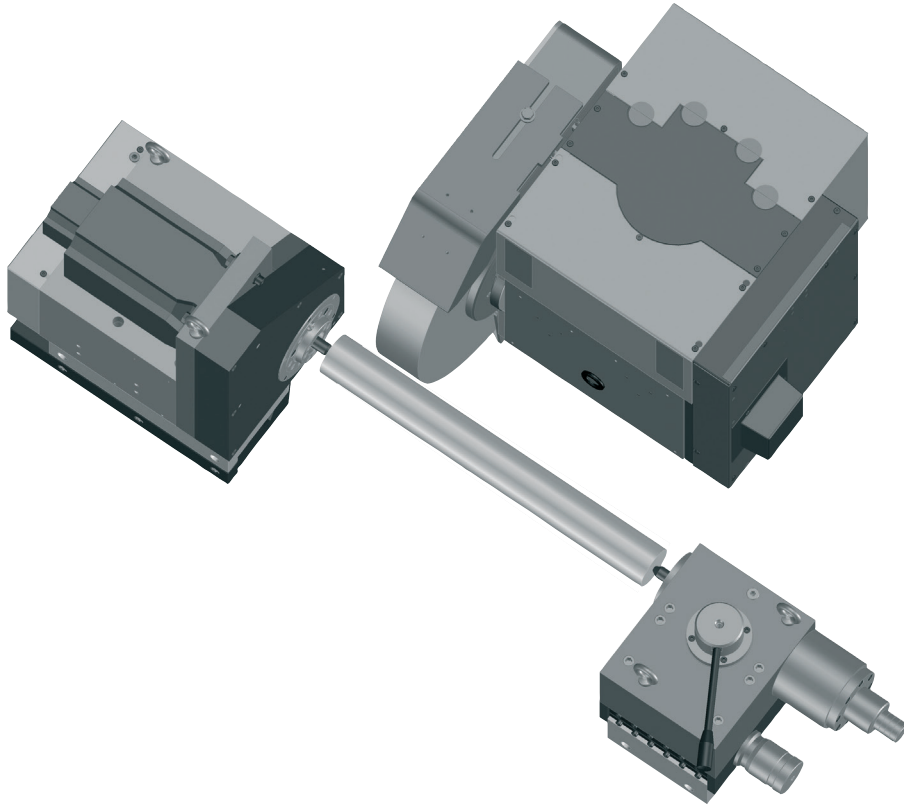

## OPTIONS

- Roundness of the workpiece  $dR < 0.2 \mu\text{m}$  ( $< 0.008 \mu\text{inch}$ ) on chucked work
- Positioned spindle stop

## C-AXIS

The option of interpolating the X- and C-axes makes it possible to use the cylindrical grinding machine also for unround shapes such as polygons, free contours and eccentric forms. The rotary encoder with a resolution of  $0.0001^\circ$  is installed directly on the workhead spindle. The non-circular movement is superimposed on the grinding movements so that the grinding machine can use all the grinding cycles on unround grinding too, including the handwheel release for the X-axis.

## TAILSTOCK

The tailstock features a large and heavy design. The nitride-coated sleeve runs in sturdy ball-bush bearings.

- Excellent rigidity makes it possible to achieve high rates of infeed even with heavy workpieces
- Sensitive sleeve pressure adjustment
- Micro-corrector for quick and easy cylinder corrections
- Pneumatic relief for tailstock movement

## OPTIONS

- Hydraulic or pneumatic sleeve retraction
- Automated cylinder correction
- Enlarged travel, 80 mm (3.14 inch)
- Reinforced design

## WORKHEAD WITH DIRECT DRIVE

- n 1-1000 min-I with direct drive 200 Spindel nose ISO 702-1, size 5
- n 1-500 min-I with direct drive 300 Spindel nose ISO 702-1, size 8

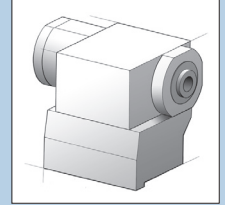

## WORKHEAD

- Standard, n 1-1000 min-I
- Spindel nose ISO 702-1, size 5
- As desired, with fixed or rotating center

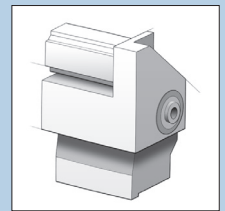

## TAILSTOCK

- Morse taper 4
- Retraction of sleeve 50 mm (1.96 inch)

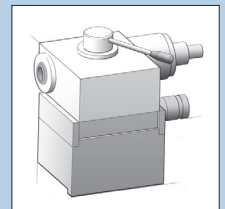

## SYNCHRONIZED TAILSTOCK

- With integrated sleeve
- Morse taper 4
- Retraction of sleeve 50 mm (1.96 inch)

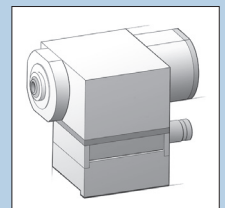

## MICRO-ADJUSTMENT

- Adjustment range  $\pm 150 \mu\text{m} / \varnothing$
- Optionally with automatic cylinder correction

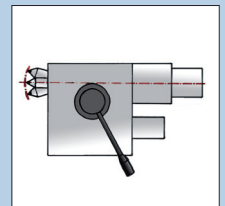

# MODULAR WHEELHEAD VARIANTS

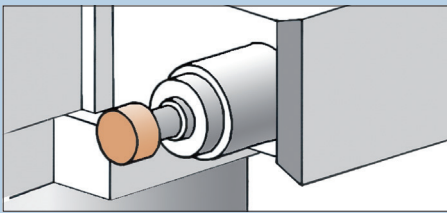
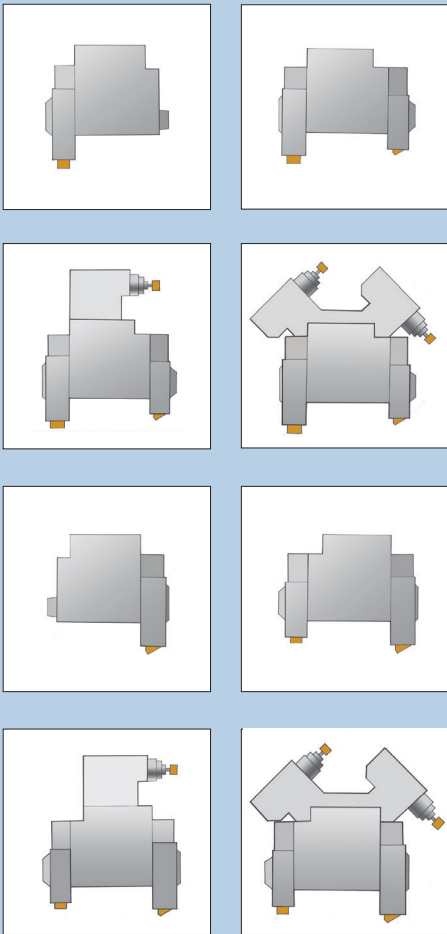

## INTERNAL GRINDING ATTACHMENT

- High-frequency internal grinding spindle

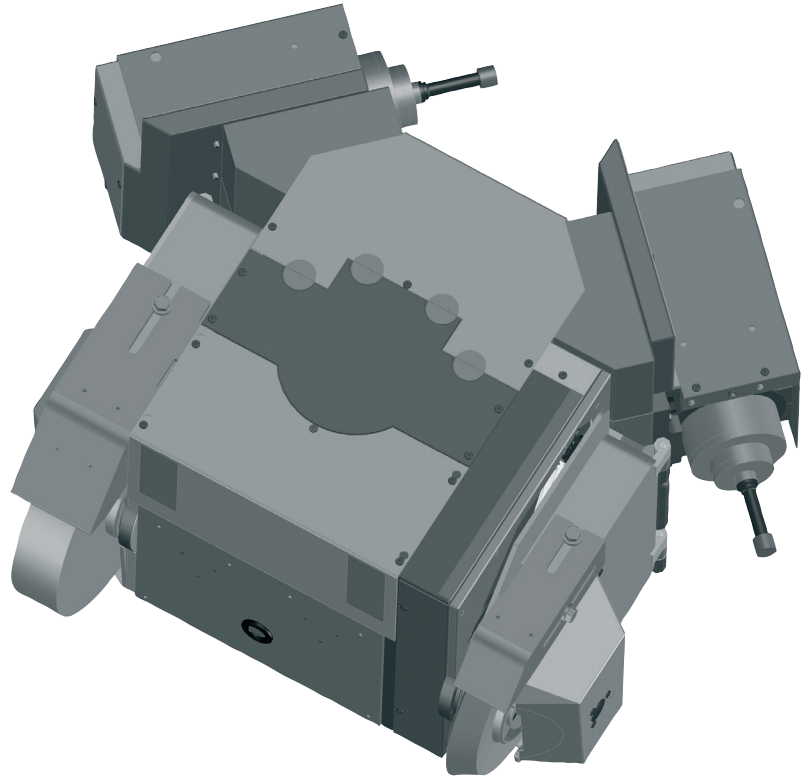

## UNIVERSAL WHEELHEADS

- Motor output 10 kW (13.6hp)
- Water-cooled precision-balanced drive motor
- Infinitely variable drive of OD and ID grinding spindles
- Hydrodynamic multi-surface spindle bearings
- Grinding wheel dimensions  
Ø 500 x 100 mm (20 x 3.15 inch)
- High-frequency ID grinding spindles

The universal wheelhead covers various user needs. In addition to external, face- and internal grinding, the use of two internal grinding spindles or the option of thread grinding or unround grinding are now increasingly in demand. Grinding in one setting allows shorter processing times and improves the quality of the workpieces considerably.

The new modular system makes it possible to supply the universal wheelhead to customer specifications, from a simple wheelhead with one tool to a configuration with up to four tools; see examples.

## DIAGONAL WHEELHEADS

- Motor output 2x 10 kW (13.6hp)
- Water-cooled precision-balanced drive motors
- Infinitely variable drive of OD and ID grinding spindles
- Hydrodynamic multi-surface spindle bearings
- Grinding wheel dimensions  
2x Ø 500 x 100 mm (20 x 3.15 inch)
- High-frequency ID grinding spindles
- Min. 2 OD grinding wheels
- Max. 2 OD grinding wheels and 2 HF ID grinding spindles

The diagonal wheelheads provide the option of rough and finish grinding in one setting. The additional use of HF ID grinding spindles also allows universal OD, face- and ID grinding.

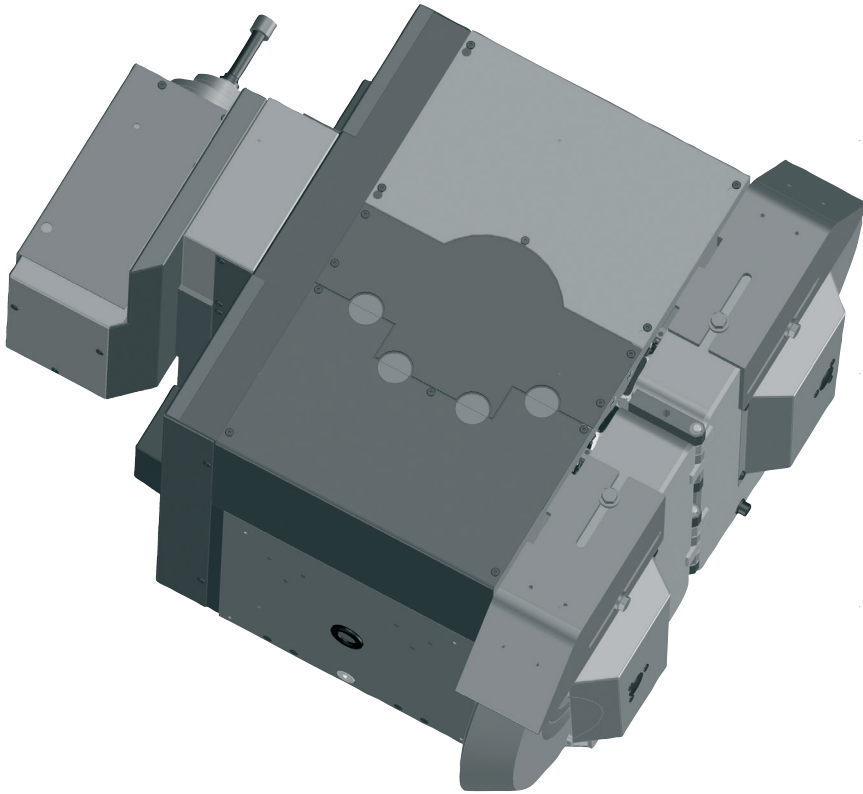

### TANDEM-TYPE WHEELHEADS

- Motor output 2x 10 kW (13.6 hp)
- Water-cooled precision-balanced drive motors
- Infinitely variable drive of OD and ID grinding spindles
- Hydrodynamic multi-surface spindle bearings
- Grinding wheel dimensions  
2x Ø 500 x 100 mm (20 x 2.5 inch)
- High-frequency ID grinding spindles
- Min. 2 OD grinding wheels
- Max. 4 OD grinding wheels or  
2-3 OD grinding wheels and 1 HF  
ID grinding spindle

The tandem-type wheelheads are designed for the possibility of carrying out straight and angular infeed operations in the same setting. With an additional HF internal grinding spindle it is possible to also process internal grinding work. The ideal equipment for these wheelheads can be determined by the nature of the workpieces to be ground.

### HF ID GRINDING SPINDLES

- MFM 1224-42
- MFM 1242-60
- Frequency converter up to 3000 Hz

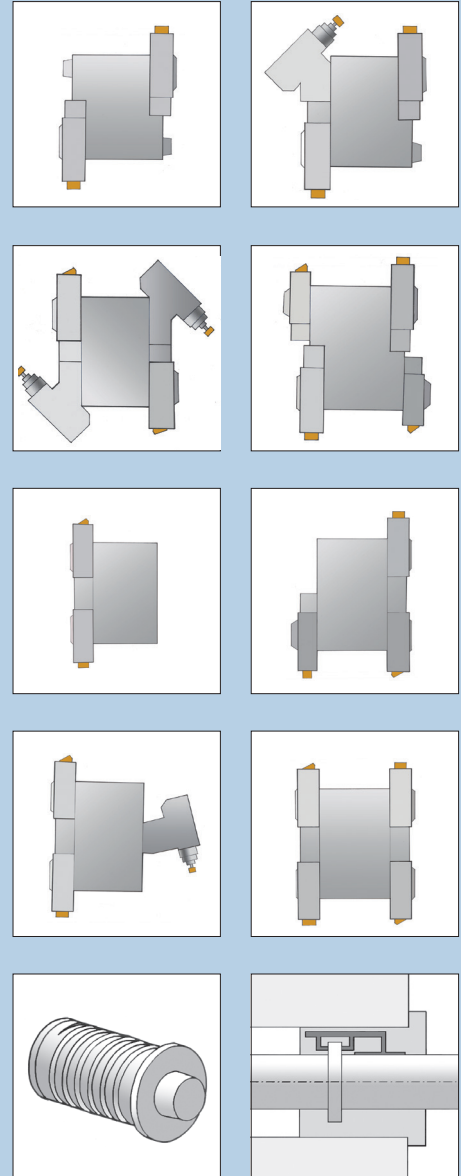

### WATER-COOLED PRECISION-BALANCED DRIVE MOTORS

### HYDRODYNAMIC MULTI-SURFACE SPINDLE BEARINGS

# HEIDENHAIN CONTROL SYSTEM GRINDPLUS 640

## MONITOR

- 19" TFT Multitouch
- Expanded process data display



## GREEN SOLUTION

### FEATURES

- Dialogue guided set-up and programming
- G-Code based
- Toll Management

### ADVANTAGE

- Safe set-up and programming
- Defined G-Codes
- Multiple tool reference points

### BENEFITS

- Ideal for high complex workpieces
- Unlimited combination of G-Codes
- Complete machining with ease



## RED SOLUTION

### FEATURE

- GRAPHIC Guide with integrated technology processor

### ADVANTAGE

- Interactive
- Visualized part programming
- Quick set-up and results

### BENEFITS

- Set-up of simple parts at minimized time
- No G-Code needed
- Less downtime

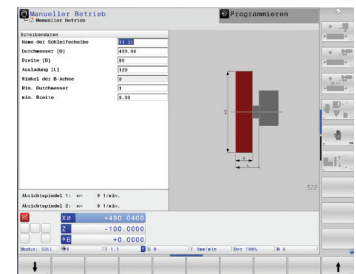
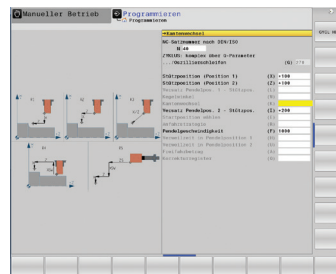

## ACOUSTIC EMISSION

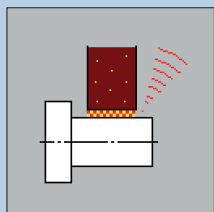

- GAP control with up to 6 sensors
- Operation and display integrated in the control system

## BALANCING

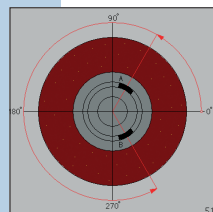

- Semi-automatic or automatic balancing of the grinding wheels
- Operation and display integrated in the control system

## IN-PROCESS GAUGE SYSTEM

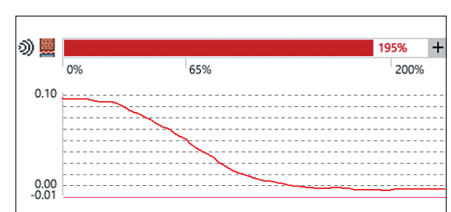

- Up to 4 gauge heads
- Interrupted diameters
- Non-interrupted diameters
- Passive longitudinal positioning



# FANUC CONTROL SYSTEM 31i



## MONITOR

- 19" TFT Touch
- Expanded process data display

## RED SOLUTION

### FEATURES

- ICON Guide
- GRAPHIC Guide with integrated technology processor

### ADVANTAGE

- Unlimited G-Code programming
- Interactive
- Visualized part programming
- Quick set-up and results

### BENEFITS

- Complex parts at minimized cycle time
- No G-Code needed
- Less downtime

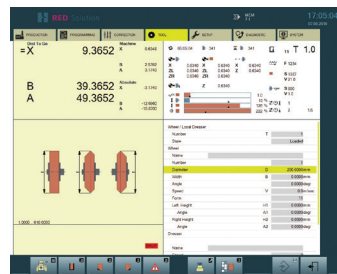
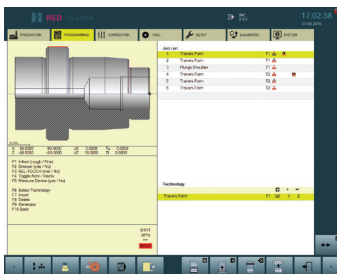

## BLACK CAM SOLUTION

### FEATURES

- Full project management
- Simplified creation of Out of round and profile contours
- Integrated technology processor
- Simple CAD system features
- Create contours and profiles or import DXF and step-files
- Error Analysis and Simulation

### ADVANTAGE

- No separate CAD system necessary
- Creation of complex contours and profiles no more challenging

- Grinding process technology available at a click

### BENEFITS

- Complex parts at minimized cycle time
- Use of the machine as its maximum performance
- Minimized risk of machine or process errors

## SECURITY INTERFACE / REMOTE DIAGNOSTICS

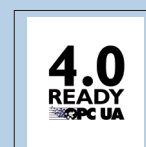

- Security Interface / Remote Diagnostics
- Highest IT Standard
- Industry 4.0 ready
- Reduced down- and waiting time
- Cost reduction at Service and Maintenance
- Preventive Maintenance

# TECHNICAL DATA

Main Specifications			Metric	Imperial
Distance Between Centres	mm	inch	1000 / 1600	40 / 63
Grinding Length	mm	inch	1000 / 1500	40 / 59
Centre Height	mm	inch	200 / 250 / 300	7.87 / 9.84 / 11.81
Weight of Workpiece Between Centres	kg	lbs	150 / 200 / 300	330 / 441 / 660
Load on Chucked Work	Nm	lbft	160 / 320 / 750	118 / 236 / 553
Mains Voltage Required			3 x 400V / 50Hz / 3 x 460V / 60Hz	3 x 400 / 50 Hz / 3 x 460V / 60Hz
Power Consumption Depending on Equipment	A	A	35-63 A	35-63 A
Space Required / Length x Width	mm	inch	3600 x 2050 / 4600 x 2050	141.73x80.70 / 181.10x80.70
Longitudinal Slides Z-Axis				
Travel	mm	inch	1170 / 1670	46.06 / 65.74
Rapid Traverse Speed	m/min	ipm	20	787
Resolution	µm	µinch	0.1	0.004
Wheelslides X-Axis				
Travel	mm	inch	365	14.37
Rapid Traverse Speed	mm	inch	10	393
Resolution	mm	inch	0.0001	0.000004
B-Axis				
Resolution			0.00002°	0.00002°
Swiveling Range			max. 240	max. 240
Wheelhead General				
Drive Motor Water-Cooled	kW	hp	10	13.4
Peripheral Grinding Wheel Speed	m/s	ft/min	max: 45 m/s	max: 8860 ft/min
Wheelhead Universal				
Grinding Wheel Dimensions, Lefthanded Side	mm	inch	400 / 500	16 / 20
Grinding Wheel Dimensions, Righthanded Side	mm	inch	300 / 400 / 500	12 / 16 / 20
Wheelhand Tandem-Type				
Grinding Wheel Dimensions, Lefthanded Side	mm	inch	400 / 500	16 / 20
Grinding Wheel Dimensions, Righthanded Side	mm	inch	400 / 500	16 / 20
Wheelhand Diagonal				
Grinding Wheel Dimensions, Lefthanded Side	mm	inch	400 / 500	16 / 20
Grinding Wheel Dimensions, Righthanded Side	mm	inch	400 / 500	16 / 20

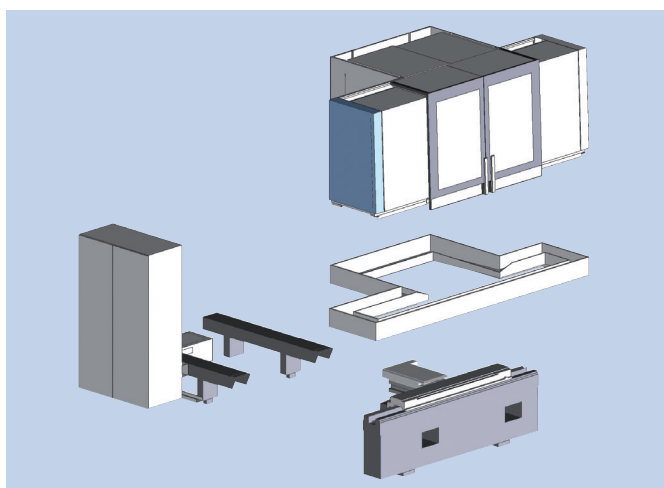

**SEPARATE INFRASTRUCTURE**

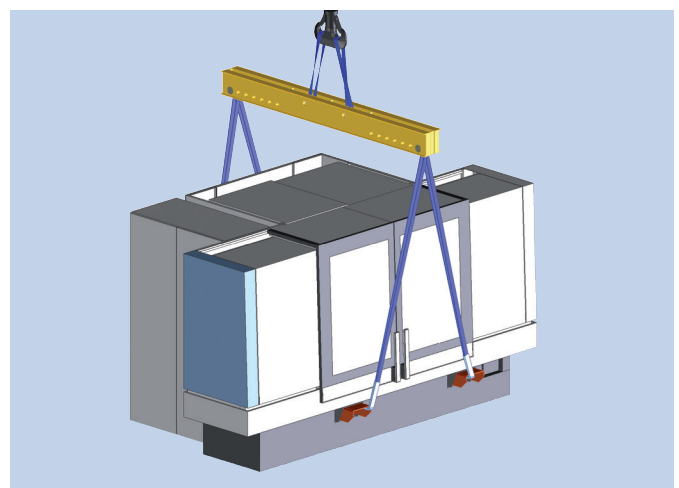

**EASY TRANSPORT**

### Internal Grinding Attachment

Bore for Spindles Up to	mm	inch	120	4.72
HF Spindles MFM	kW	hp	10 / 15	13.4 / 20.1
Rotational Speed I224 / 42	min-l	rpm	42,000	42,000
Rotational Speed I242 / 60	min-l	rpm	60,000	60,000

### Workhead Standard/Direction Drive

Rotational Spindle Speed	min-l	rpm	I-1000 / I-1000 / I-500	I-1000 / I-1000 / I-500
Internal Taper			MT5 / MT5 / MT6	MT5 / MT5 / MT6
Short Taper Holder, Outside			ISO 702-I : Size 5 / Size 5 / Size 8	ISO 702-I : Size 5 / Size 5 / Size 8
Micro-Adjustment	sec	sec	+/- 60	+/- 60

### Tailstock

Internal Taper			MT4	MT4
Retraction of Sleeve	mm	inch	50 optional 80	1.96 optional 3.15
Micro-Adjustment	µm	µinch	+/- 150	+/- 6

### CNC Control System

Heidenhain	GRINDplus 640
Fanuc	Fanuc 3li

All specifications and designs are subject to alterations without notice

### SPACE-ASSIGNMENT PLAN 1000

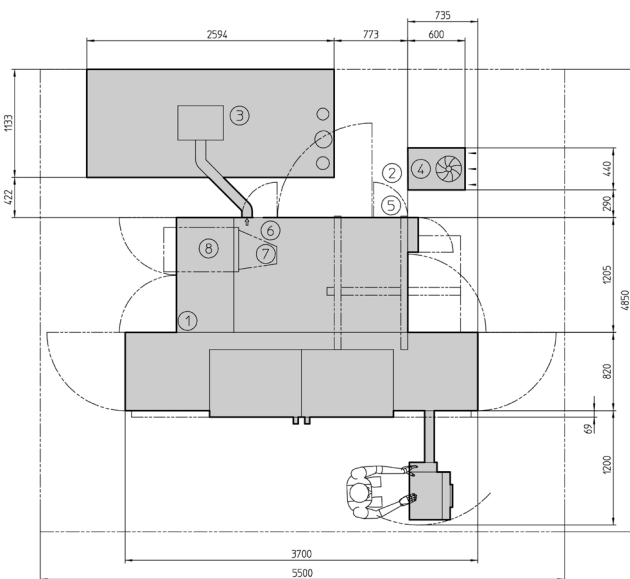

### SPACE-ASSIGNMENT PLAN 1600

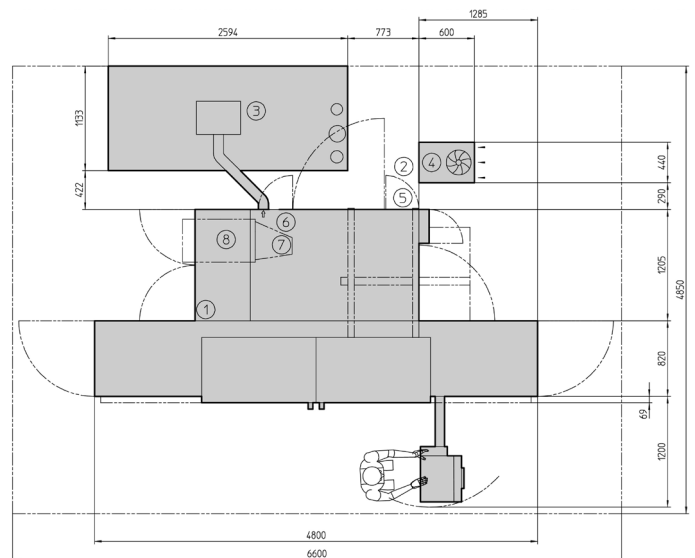

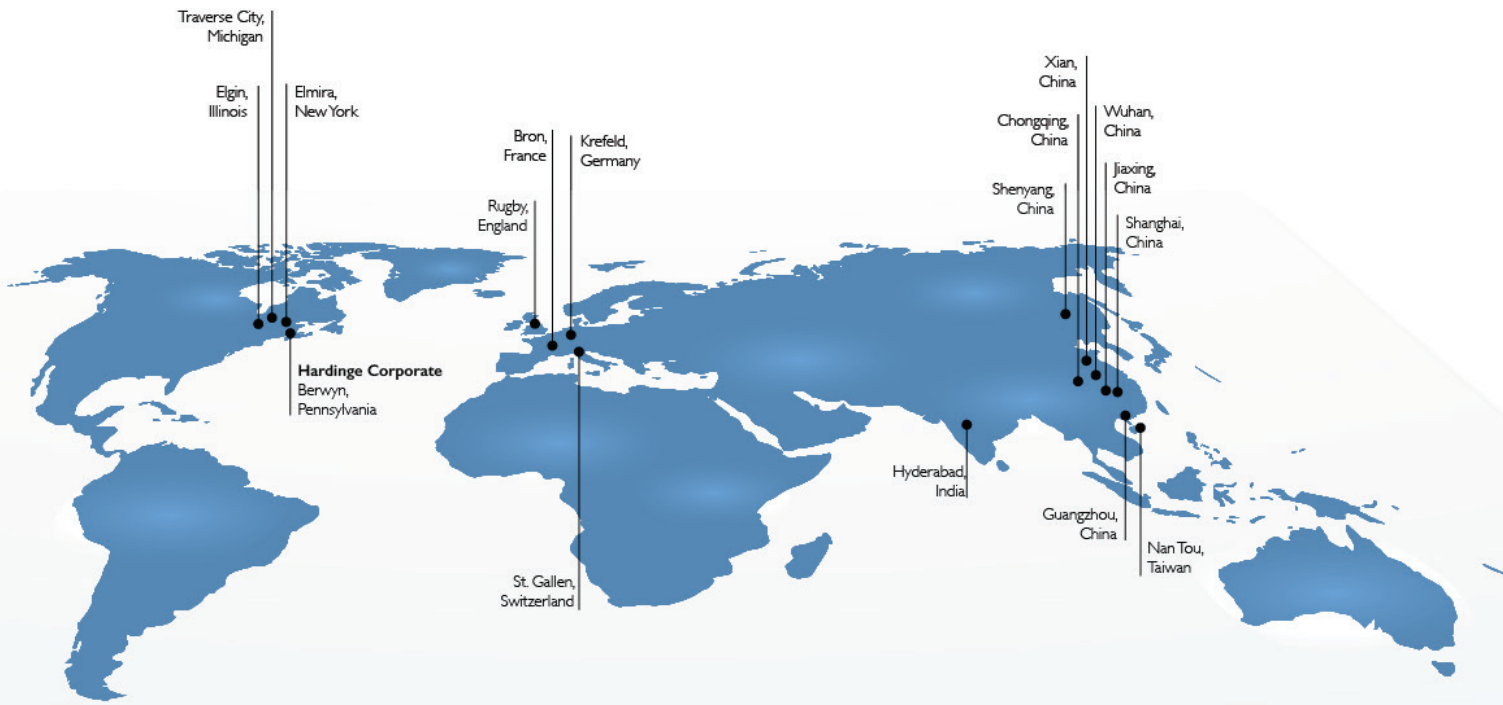

## HARDINGE WORLDWIDE

Hardinge is a leading international provider of advanced metal-cutting solutions. We provide a full spectrum of highly reliable CNC turning, milling, and grinding machines as well as technologically advanced work-holding accessories.

The diverse products we offer enable us to support a variety of market applications in industries including aerospace, agricultural, automotive, construction, consumer products, defense, energy, medical, technology, transportation and more.

We've developed a strong global presence with manufacturing operations in North America, Europe, and Asia. Hardinge applies its engineering and applications expertise to provide your company with the right machine tool solution and support every time.

### AMERICAS

**Pennsylvania**  
Hardinge Corporate  
1235 Westlakes Drive  
Suite 410  
Berwyn, PA 19312

**New York**  
Hardinge  
One Hardinge Drive  
Elmira, NY 14903  
P. 800-843-8801  
E. [info@hardinge.com](mailto:info@hardinge.com)  
[www.hardinge.com](http://www.hardinge.com)

**Illinois**  
Hardinge  
1524 Davis Road  
Elgin, IL 60123  
P. 800.843.8801

### ASIA

**China**  
Hardinge Machine  
(Shanghai) Co. Ltd.  
1388 East Kangqiao Road  
Pudong, Shanghai 201319  
P. 0086 21 3810 8686

**Taiwan**  
Hardinge Taiwan Precision  
Machinery Limited  
4 Tzu Chiang 3rd Road  
Nan Tou City 540  
Taiwan  
P. 886 49 2260 536  
E. [cs@hardinge.com.tw](mailto:cs@hardinge.com.tw)

### EUROPE

**France**  
Jones & Shipman SARM  
8 Allee des Ginkgos  
BP 112-69672  
Bron Cedex, France

**Germany**  
Hardinge GmbH  
Fichtenhain A 13c  
47807 Krefeld  
P. 49 2151 49649 10  
E. [info@hardinge-gmbh.de](mailto:info@hardinge-gmbh.de)

**Switzerland**  
L. Kellenberger & Co. AG  
Heiligkreuzstrasse 28  
CH 9008 St. Gallen  
Switzerland  
P. 41 71 2429111  
E. [info@kellenberger.net](mailto:info@kellenberger.net)

**United Kingdom**  
Jones & Shipman  
Hardinge Ltd.  
Europark, Unit 4 Watling Street  
Rugby CV23 0AL, England  
P. 44 116 201 3000  
E. [info@jonesshipman.com](mailto:info@jonesshipman.com)



[WWW.HARDINGE.COM](http://WWW.HARDINGE.COM)

All prices and specifications are subject to change without notice.  
All marks indicated by ® and ™ are trademarks of their respective owners.  
#1201-1E © Hardinge Inc. • 07/19